

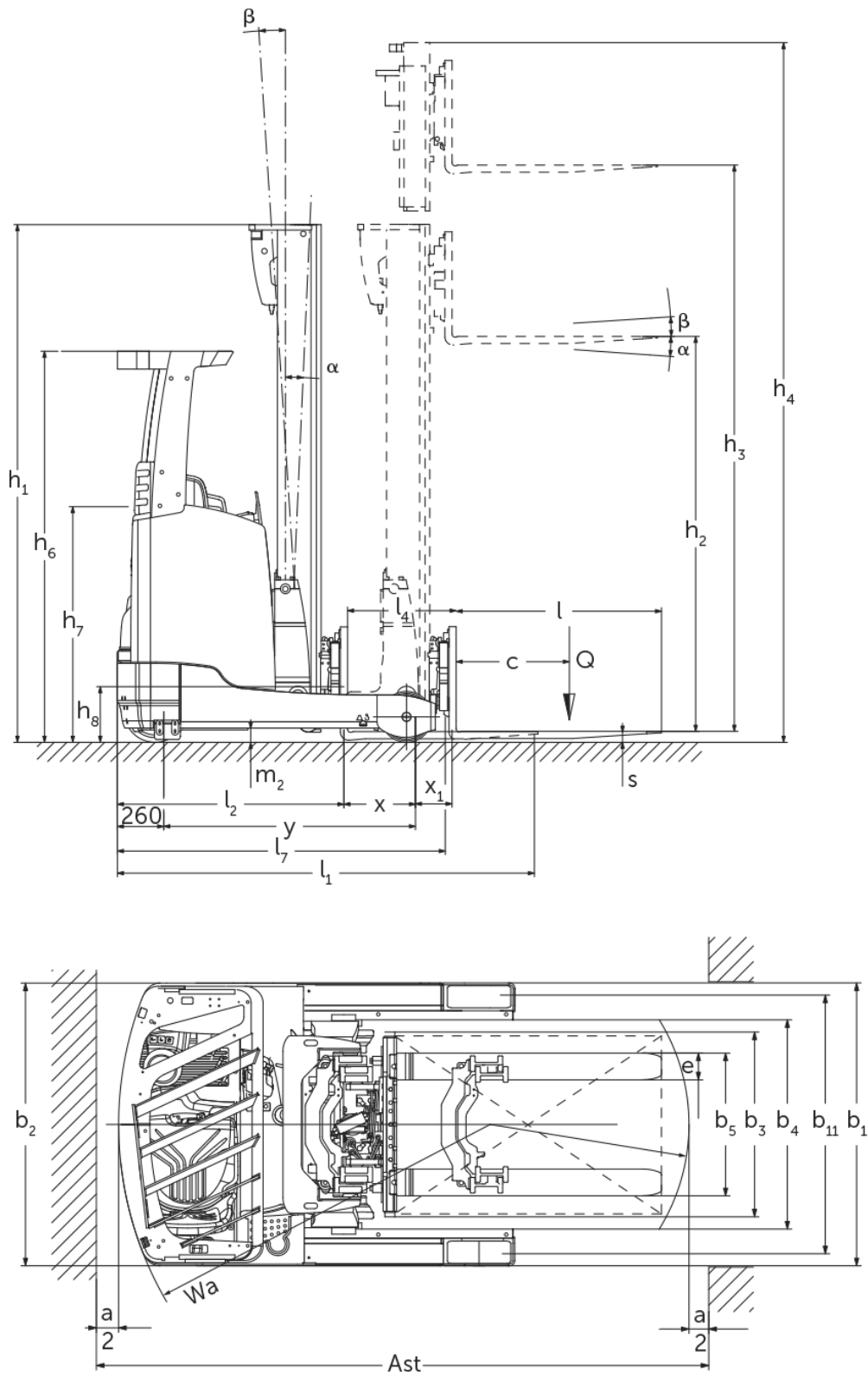

Electric reach truck **ETV/ETM 210 - 216**

Lift height: 4550-10700 mm / Load capacity: 1000-1600 kg

ETV/ETM 210 - 216



ETV/ETM 210 - 216

ETM 214, ETV 214, ETM 216, ETV 216	Lift (h3)	Retracted mast height (h1)	Free lift (h2)	Extended mast height (h4)	Forward/backward tilt of mast	Forward/backward tilt of fork carriage
Mast tilt / Triplex mast DZ / cold-formed	6500 mm	2700 mm	2046 mm	7154 mm	0.5 / 2 °	
	6800 mm	2800 mm	2146 mm	7454 mm	0.5 / 2 °	
	7100 mm	2900 mm	2246 mm	7754 mm	0.5 / 2 °	
	7310 mm	2970 mm	2316 mm	7964 mm	0.5 / 1 °	
	7400 mm	3000 mm	2346 mm	8054 mm	0.5 / 1 °	
	7700 mm	3100 mm	2446 mm	8354 mm	0.5 / 1 °	
	8000 mm	3200 mm	2546 mm	8654 mm	0.5 / 1 °	
	8300 mm	3300 mm	2646 mm	8954 mm	0.5 / 1 °	
	8420 mm	3340 mm	2686 mm	9074 mm	0.5 / 1 °	
	8720 mm	3440 mm	2786 mm	9374 mm	0.5 / 1 °	
	9020 mm	3540 mm	2886 mm	9674 mm	0.5 / 1 °	
ETV 210, ETV 212, ETM 214, ETV 214, ETM 216, ETV 216	Lift (h3)	Retracted mast height (h1)	Free lift (h2)	Extended mast height (h4)	Forward/backward tilt of mast	Forward/backward tilt of fork carriage
Mast tilt / Triplex mast DZ / hot-rolled	4550 mm	2050 mm	1396 mm	5204 mm	1 / 5 °	
	5000 mm	2200 mm	1546 mm	5654 mm	1 / 5 °	
	5240 mm	2280 mm	1626 mm	5894 mm	1 / 5 °	
	5300 mm	2300 mm	1646 mm	5954 mm	1 / 5 °	
	5450 mm	2350 mm	1696 mm	6104 mm	1 / 3 °	
	5600 mm	2400 mm	1746 mm	6254 mm	1 / 3 °	
	5720 mm	2440 mm	1786 mm	6374 mm	1 / 3 °	
	5900 mm	2500 mm	1846 mm	6554 mm	1 / 3 °	
	6200 mm	2600 mm	1946 mm	6854 mm	1 / 3 °	
	6500 mm	2700 mm	2046 mm	7154 mm	0.5 / 2 °	
	6800 mm	2800 mm	2146 mm	7454 mm	0.5 / 2 °	
	7100 mm	2900 mm	2246 mm	7754 mm	0.5 / 2 °	
	7310 mm	2970 mm	2316 mm	7964 mm	0.5 / 1 °	
	7400 mm	3000 mm	2346 mm	8054 mm	0.5 / 1 °	
ETV 214, ETV 216	Lift (h3)	Retracted mast height (h1)	Free lift (h2)	Extended mast height (h4)	Forward/backward tilt of mast	Forward/backward tilt of fork carriage
Fork tilt / Triplex mast DZ / cold-formed	5000 mm	2200 mm	1546 mm	5654 mm	2 / 5 °	
	5300 mm	2300 mm	1646 mm	5954 mm	2 / 5 °	
	5600 mm	2400 mm	1746 mm	6254 mm	2 / 5 °	
	5900 mm	2500 mm	1846 mm	6554 mm	2 / 5 °	
	6200 mm	2600 mm	1946 mm	6854 mm	2 / 5 °	
	6500 mm	2700 mm	2046 mm	7154 mm	2 / 5 °	
	6800 mm	2800 mm	2146 mm	7454 mm	2 / 5 °	
	7100 mm	2900 mm	2246 mm	7754 mm	2 / 5 °	
	7400 mm	3000 mm	2346 mm	8054 mm	2 / 5 °	
	7700 mm	3100 mm	2446 mm	8354 mm	2 / 5 °	
	8000 mm	3200 mm	2546 mm	8654 mm	2 / 5 °	
	8300 mm	3300 mm	2646 mm	8954 mm	2 / 5 °	
	8420 mm	3340 mm	2686 mm	9074 mm	2 / 5 °	
	8720 mm	3440 mm	2786 mm	9374 mm	2 / 5 °	
	9020 mm	3540 mm	2886 mm	9674 mm	2 / 5 °	
9410 mm	3670 mm	3016 mm	10064 mm	2 / 5 °		
9920 mm	3840 mm	3186 mm	10574 mm	2 / 5 °		

10250 mm	3950 mm	3296 mm	10904 mm	2 / 5 °
10520 mm	4040 mm	3386 mm	11174 mm	2 / 5 °
10700 mm	4100 mm	3446 mm	11354 mm	2 / 5 °

VDI table

Stand-on: 06/2022

Characteristic	1.1	Manufacturer (abbreviated description)	Jungheinrich							
	1.2	Manufacturer's type designation	ETV 210	ETV 212	ETM 214	ETV 214	ETM 216	ETV 216		
Characteristic	1.3	Drive	Electric							
	1.4	Operation	Sideways-seated							
	1.5	Load capacity/load	Q kg	1000	1200	1400		1600		
	1.6	Load centre distance	c mm	600						
	1.8	Load distance, centre of drive axle to fork	x mm	315	400	353	423	403	413	
	1.8.1	Load distance, centre of drive axle to fork, mast extended	mm	170		205				
	1.9	Wheelbase	y mm	1300	1385	1410		1460		
	Weights	2.1.1	Service weight (incl. battery)	kg	2560	2580	2975	3000	3110	3136
		2.3	Axle load unladen front/rear	kg	1587 / 973	1587 / 993	1785 / 1190	1830 / 1170	1835 / 1275	1882 / 1254
2.4		Axle load fork forward laden front/rear	kg	634 / 2926	516 / 3264	481 / 3894	572 / 3828	518 / 4192	521 / 4215	
2.5		Axle load fork back laden front/rear	kg	1282 / 2278	1361 / 2419	1531 / 2844	1628 / 2772	1649 / 3061	1658 / 3078	
Wheels/suspension system	3.1	Tyres	Polyurethane (PU)							
	3.2	Tyre size, front	Ø 343 x 114							
	3.3	Tyre size, rear	Ø 230 x 85		Ø 285 x 100					
	3.5	Wheels, number front/back (x=driven)	1x / 2							
	3.7	Tread width, rear	b ₁₁ mm	993		986	1136	986	1136	
Basic dimensions	4.1	Forward/backward tilt of mast	a/β °	1 / 3						
	4.2	Retracted mast height (h1)	h ₁ mm	2300		2400				
	4.3	Free lift (h2)	h ₂ mm	1646		1746			1756	
	4.4	Lift (h3)	h ₃ mm	5300		5600				
	4.5	Extended mast height (h4)	h ₄ mm	5954		6254			6244	
	4.7	Height of overhead guard (cab)	h ₆ mm	2190						
	4.8	Seat height/stand height	h ₇ mm	1057						
	4.10	Height of support arms	h ₈ mm	265		285				
	4.19	Overall length	l ₁ mm	2321		2418	2346	2418	2408	
	4.19.4	Length including fork length	l ₁ mm	2346		2418	2348	2418	2408	
	4.20	Length including fork shank	l ₂ mm	1196		1268	1198	1268	1258	
	4.21.1	Overall width	b ₁ mm	1120			1270	1120		1270
	4.21.2	Overall width	b ₂ mm	1120			1270	1120		1270
	4.22	Fork dimensions	s/e/l mm	40 x 80 x 1150			40 x 120 x 1150			
	4.23	Fork carriage connection class	2B							
	4.24	Fork carriage width	b ₃ mm	800		830				
	4.25	Width across forks	b ₅ mm	296		335				
	4.25.1	Width across forks (min.)	b ₅ mm	296		335				
	4.26	Width between support arms/loading areas	b ₄ mm	900		780	940	780	940	
	4.28	Reach distance	mm	485	570	558	628	608	618	
	4.32	Ground clearance centre of wheelbase	m ₂ mm	80						
	4.34.1	Aisle width (pallet 1000x1200 sideways)	Ast mm	2626	2644	2702	2652	2716	2709	
	4.34.2	Aisle width (pallet 800x1200 length)	Ast mm	2686	2689	2757	2694	2762	2753	
4.35	Turning radius	W _a mm	1515		1595		1620		1670	
4.37	Length over the support arms	L ₇ mm	1640		1725		1780		1830	

Performance data	5.1	Travel speed laden/unladen (Efficiency drivePLUS)	km/h	-	11 / 11 14 / 14				
	5.2	Lift speed laden/unladen (Efficiency liftPLUS)	m/s	-	0.38 / 0.7	0.51 / 0.7	0.35 / 0.7 0.48 / 0.7		
	5.3	Lowering speed laden/unladen (Efficiency liftPLUS)	m/s	-	0.55 / 0.55 0.55 / 0.55				
	5.4	Reach speed laden/unladen (Efficiency liftPLUS)	m/s	-	0.18 / 0.18 0.22 / 0.22				
	5.7	Gradeability laden/unladen (Efficiency drivePLUS)	%	-	9 / 13 9 / 13		8 / 12 8 / 12		
	5.8	Max. gradeability laden/unladen (Efficiency drivePLUS)	%	-	10 / 15 10 / 15				
	5.9	Acceleration time laden/unladen (Efficiency drivePLUS)	s	-	5.3 / 5 4.7 / 4.3		5.4 / 5 4.8 / 4.3		
	5.10	Service brake			electric				
	E-motor/Electronics	6.1	Drive motor, performance S2 60 min (Efficiency drivePLUS)	kW	-	6 8.5			
		6.2	Lift motor, performance with S3 (Efficiency liftPLUS)	kW	-	13.3 15.5			
6.3		Battery according to DIN 43531/35/36			DIN 43531 B		DIN 43531 C	DIN 43531 B	DIN 43531 C
6.4		Battery voltage/nominal capacity	V / Ah	48 / 280	48 / 465				
6.5		Battery weight	kg	556	750				
6.6.1		Energy consumption according to EN cycle (Efficiency PLUS)	kWh/h	-	3.16 3.21		3.19 3.23		
6.6.2		CO2 equivalent as per EN 16796 (Efficiency PLUS)	kg/h	-	1.7 1.7				
6.7		Throughput (Efficiency PLUS)	t/h	-	52.34 60.8		58.42 68.74		
6.8.1		Energy consumption with max. throughput (Efficiency PLUS)	kWh/h	-	3.08 4.04		3.22 4.11		
Other	8.1	Type of drive control		Impulse / Mosfet AC	Mosfet/AC				
	10.1	Operating pressure for attachment	bar	150					
	10.2	Oil flow for attachments	l/min	20					
	10.7	Sound level as per EN12053, operator's ear	dB (A)	68					

- This data sheet according to VDI guideline 2198 only states the technical values of the standard truck. Different tyres, other masts, additional equipment etc. may result in different values.

Efficiency: Values of standard package | PLUS: Values of performance package

- VDI no. 1.8: battery size and mast type affect load distance x
- VDI no. 2.1.1: battery size and mast version affect service weight and axle loads
- VDI no. 2.3: battery size and mast version affect service weight and axle loads
- VDI no. 2.4: battery size and mast version affect service weight and axle loads
- VDI no. 2.5: battery size and mast version affect service weight and axle loads
- VDI no. 4.1: the mast version determines the tilt values
- VDI no. 4.10: the height of the support arms is enlarged by 30 mm with a load support arm cover
- VDI no. 4.19: battery size, mast type and fork length affect the overall length l1
- VDI no. 4.20: battery size and mast type affect the length including fork shank l2
- VDI no. 4.28: battery size and mast type affect the reach distance l4
- VDI no. 4.34.1: battery size and mast type affect the aisle widths
- VDI no. 4.34.2: battery size and mast type affect the aisle widths
- VDI no. 6.6.1: PLUS refers to the drive&liftPLUS performance package
- VDI no. 6.6.2: PLUS refers to the drive&liftPLUS performance package
- VDI no. 6.7: PLUS refers to the drive&liftPLUS performance package
- VDI no. 6.8.1: PLUS refers to the drive&liftPLUS performance package

The German production facilities in
Norderstedt, Moosburg and Landsberg
are certified.

ISO 9001
ISO 14001

Jungheinrich fork lift trucks meet
European safety requirements.



 **JUNGHEINRICH**

The Jungheinrich logo, featuring a red upward-pointing arrow above the word 'JUNGHEINRICH' in a bold, black, sans-serif font.